

Combining MEMS accelerometers with MicroStrain's award winning Micro Datalogging Transceiver systems, G-Link is a high speed, triaxial accelerometer node, designed to operate as part of an integrated wireless sensor network system.

The Base Station transceiver may trigger data logging (from 30 meters), or request previously logged data to be transmitted to the host PC for data acquisition/display/analysis. Featuring two KHz sweep rates, combined with two Megabytes of flash memory, these little nodes pack a lot of power in a small package. Every node in the wireless network is assigned a unique 16 bit address, so a single host transceiver can address thousands of multichannel sensor nodes. The Base Station can trigger all the nodes simultaneously, with timing data sent by the Base Station, along with the trigger command. These timing data are logged by the sensor nodes along with their sensed data.

G-Link may also be wirelessly commanded to transmit data continually, at 1 KHz sweep rates, for a pre-programmed time period. The continuous, fast wireless transmission mode allows for real time data acquisition and display from a single multichannel sensor node at a time.

These small, fast, wireless data recording systems can be used to monitor tilting, vibrating, and rotating machinery, equipment, and structures. Users can monitor a large number of wireless sensors over a relatively wide area, distributed over many different machines, subjects, and locations.

#### **APPLICATIONS**

- inclination & vibration testing, control
- security systems enabled by wireless sensor networks
- assembly line testing with "smart packaging"
- sports performance and sports medicine analysis
- condition based maintenance by wireless sensor networks
- smart machines, smart structures, & smart materials

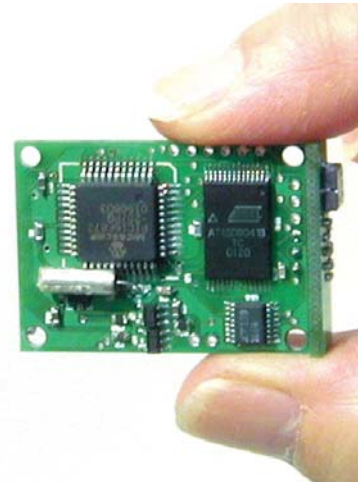

**Gold**

# G-LINK WIRELESS ACCELEROMETER SYSTEM

## ELECTRICAL & MECHANICAL SPECIFICATIONS

On-Board Accelerometers:	<i>triaxial MEMS accelerometers, Analog Devices' ADXL2XXJE</i>
Acceleration Range:	<i>+/- 2 G's or +/- 10 G's</i>
Shock Limits:	<i>500 G's</i>
Data Acquisition Modes:	<i>Mode 1: autotrigger, user specified as a programmable output voltage from a specific channel Mode 2: on command from RS-232 or RF link Mode 3: transmit continually for pre-programmed time period</i>
DAS Software:	<i>Windows 95/98/2000/XP, PC compatible</i>
Analog to Digital (A/D) converter:	<i>successive approximation type, 12 bits resolution</i>
Data Storage Capacity:	<i>2 megabytes (~ one million data points)</i>
Datalogging Sample Rate:	<i>programmable, from 32 to 2048 sweeps/second (one sweep represents one sample from all active channels)</i>
Continuous Transmission Sample Rate:	<i>1000 sweeps of all three channels per second</i>
Data Sample Duration:	<i>programmable from 1 to 65,535 data sweeps; for 2048 sweeps per second, sample duration is 32 seconds</i>
G-Link Node input power:	<i>3.6 volt lithium ion _AA size internal battery recommended, 2400 milliamp-hour capacity standard; or customer may supply external power from 3.1 to 9 volts</i>
G-Link Battery Lifespan:	<i>273 hours (estimated, using 80% @ 6 milliamps current draw and sensor RF receive link active, 20% @ 20 milliamps w/ sensor RF transmit link active)</i>
Radio Frequency (RF) Transceiver Carrier:	<i>916 MHz, narrowband, FCC compliant, license free use in USA</i>
Range for Base Station RF Trigger:	<i>100 feet (30 meters) typical, line of sight</i>
Range for Bi-Directional RF link:	<i>100 feet typical, line of sight</i>
RF Programming & Downloading:	<i>19200 baud, wireless RF, pulse code modulated, ASK</i>
RS-232 Programming & Downloading:	<i>38400 baud direct serial RS-232 cable w/ miniature connector</i>
G-Link Sensor Transceiver PCB size:	<i>25 mm by 39 mm by 7.25 mm</i>
Base Station Enclosure size:	<i>110 mm by 75mm by 37 mm</i>
Operating Temperature:	<i>-40 to +85 deg C</i>

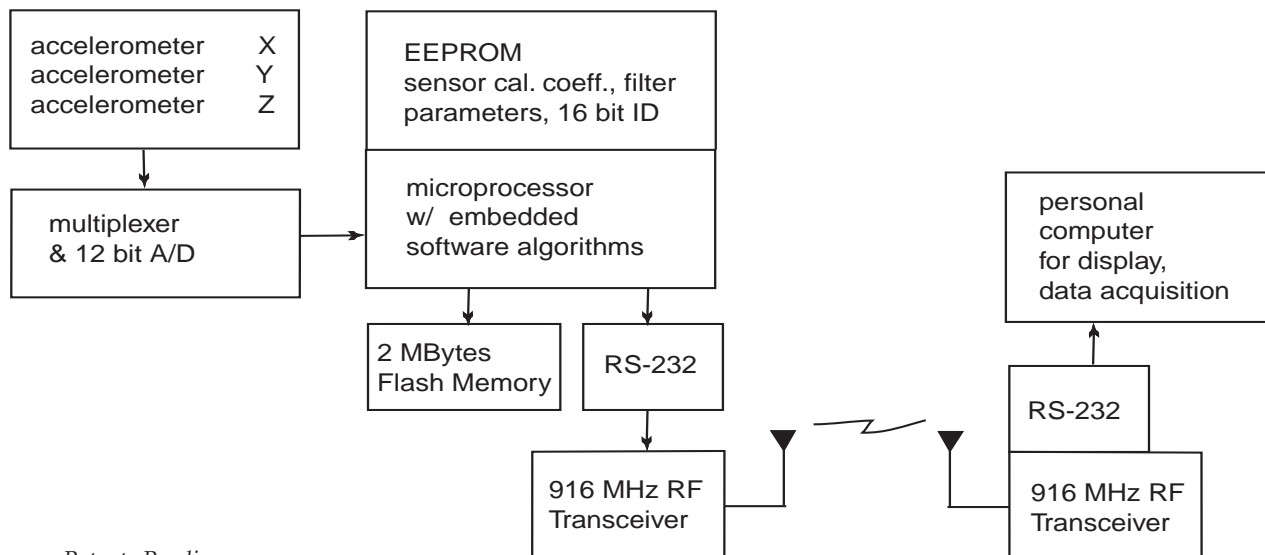

Patents Pending