

## SERIES M

# Differential Pressure Transmitters



## DESCRIPTION

The Series M family of differential pressure transmitters measure low pressures and feature a wide variety of analog signal outputs with low power consumption. A wide selection of standard pressure ranges and electrical ratings is available.

These transmitters feature: no moving parts to wear out, reliable long term stability, and are virtually position insensitive.

The Series M transmitters are typically used for monitoring cleanroom pressures, HVAC, velocity pressures, bubbler level systems, and leak detection; as well as filter differential, draft, fume hood and other low pressure applications.

The transmitters are housed in a compact heavy duty gasketed cast aluminum enclosure designed to IP 65 of IEC 529 standards and NEMA 4. The die cast aluminum enclosure incorporates a recessed neoprene gasket to prevent ingress of moisture or dust. Wall mounting holes are enclosed in the cast aluminum box and concealed by the cover. The wall mounting holes and the cover attaching screws are outside the gasketed area. Access to the terminals are made through knockouts on the front of the box. A choice of one or two knockouts and three hole sizes is available to accommodate usage of 1/2 inch conduit and metric sizes PG11 and PG13.

Pluggable terminal block connectors are provided with captive wire protection and captive terminal screws.

The Series M includes four models: Model M10, Model M20, Model M30 and Model M40.

These four models incorporate a variety of power and signal options.

The span or zero adjustment is performed with a 20 turn potentiometer for fine resolution.

The M Series transmitters have been tested by an accredited laboratory and comply with the European requirements of Council Directive 89/336/EEC for emission measurements per EN50081-1 and immunity tests per EN50082-1.

<b>M10</b>	3-Wire DC Voltage In DC Voltage Out	<b>M30</b>	2-Wire DC Voltage In 4 - 20 mA Out
<b>M20</b>	4-Wire 24, 120, or 240 Vac In DC Voltage Out	<b>M40</b>	4-Wire 24, 120, 240 Vac In 4-20 mA Out

## OPERATION

The pressure sensing element is a differential capacitance cell for pressure measurements ranging from 0.1 to 5 inches of water (25 Pa to 1.0 kPa), or piezoresistive (silicon) sensors for pressure measurements ranging from 5 inches of water to 30 psi (1.0 kPa to 200kPa).

The capacitance cell is capable of sensing very low pressures, negative or differential pressures. A very lightweight, responsive diaphragm within the cell deflects a small amount when a small pressure is applied. This deflection results in a change in capacitance which is then detected and amplified electronically.

The piezoresistive sensor is a solid state device designed in a Wheatstone bridge configuration. When pressure is applied to the device, the resistance of the bridge changes by a small amount. The output of the bridge is ratiometric to the supply voltage, and a small change in resistance is detected as a change in output voltage.

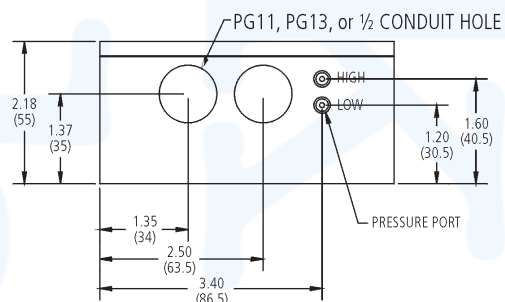
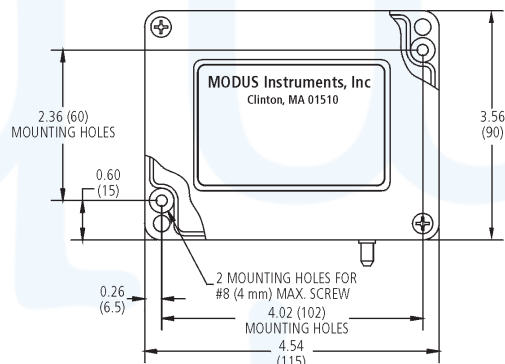

DIMENSIONS ARE IN INCHES (MILLIMETERS)

## SPECIFICATIONS

### Performance Specification

Accuracy:  $\pm 1\%$  of Span (including non-linearity and hysteresis)

Calibration: (Traceable to N.I.S.T.)

### Environmental

Operating temperature range:  $0^{\circ}\text{C}$  to  $45^{\circ}\text{C}$  ( $32^{\circ}\text{F}$  to  $115^{\circ}\text{F}$ )

Storage temperature:  $-30^{\circ}\text{C}$  to  $70^{\circ}\text{C}$  ( $-20^{\circ}\text{F}$  to  $160^{\circ}\text{F}$ )

Effect of temperature on zero:  $\pm 0.05\%/^{\circ}\text{C}$

on span:  $\pm 0.02\%/^{\circ}\text{C}$

Operating humidity range: 10% to 90% R.H. non-condensing

Shock resistance: 10G (11ms)

Vibration resistance: 5G to 50 Hz

### Electrical Connectors

Polarized Euro plug/connectors

Connections: Pluggable terminal block for wire 14 to 26 AWG

Material: Glass filled polyester

### Physical

Dimensions: 3.56"x4.54"x2.18" (90 x115 x55 mm)

Material: Aluminum Alloy #A380

Cover screws: M4 Stainless Steel non-magnetic

Finish: Black epoxy paint

Knockout: choice of 1 or 2 holes. Knockout hole sizes 1/2" conduit, PG11 or PG13

Cable glands not included

Pressure port connection: 3/16" Dia. suitable for:

-1/8" I.D. Tygon™ or polyurethane tubing (3 - 4 mm)

-1/4" O.D. polyethylene tubing (6mm)

Weight: 1.27 lb max (576 g)

Integral filters at both ports

Measures differential, gage pressure or vacuum

Suitable for air or inert gases

## MODEL M10

### DC Power Input/Voltage Output

Diagram shows area of detail.

Please see inset diagrams for wiring of each individual model below.

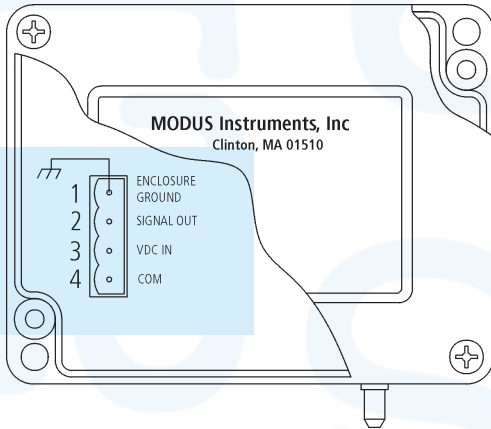

## SPECIFICATIONS

### Electrical

Supply Voltage: 11 to 32 Vdc (14.5 to 32 Vdc for 10 Volts output)

Protected against reversal of polarity

Supply Current: 8mA

Output:

0 to 5 Volts, linear

0 to 10 Volts linear

Sink or source 3.5mA

Protected against short circuit

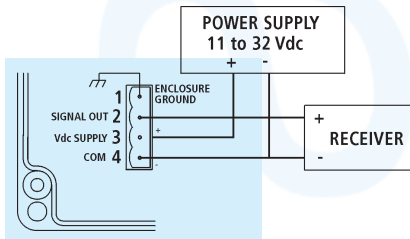

Terminal 1 is enclosure ground.

Terminal 2 is positive signal voltage.

Terminal 3 is positive supply voltage.

Terminal 4 is common to both the DC power supply and the output signal.

## MODEL M20

### AC Power Input/Voltage Output

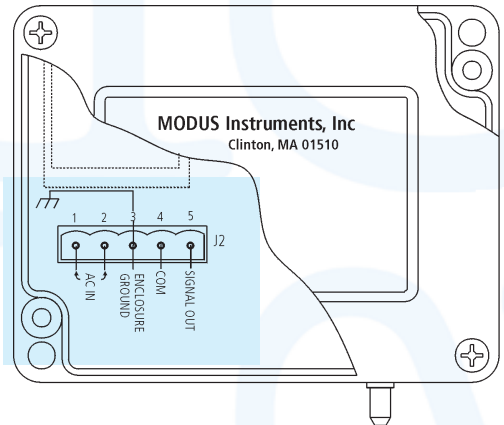

## SPECIFICATIONS

### Electrical

Nominal Input Voltage	Power Consumption	Operating Voltage Range
24 Vac	1.5W	20 to 32 Vac
120 Vac	1.5W	90 to 140 Vac
240 Vac	1.5W	180 to 260 Vac

Output can sink or source 3.5mA

Output voltage is protected against short circuit

Isolation between power supply and output is 2500 Vrms

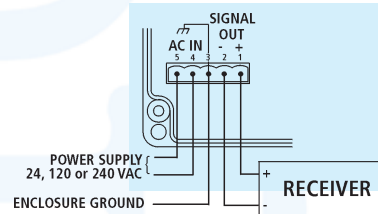

Terminals 1 and 2 are DC voltage output.

Terminal 3 is ground.

Terminals 4 and 5 are AC power input.

## ORDERING INFORMATION

### Order Number

(See Table below and Reference Table A)

M10 - IP - O - SO - KQ - KS

EXAMPLE:

M10 - 01E - A - 5 - 1 - R

IP = Input Pressure	O = Offset (See Note 1)	SO = Signal Output	KQ = Knockout Quantity	KS = Knockout Size
See Reference Table A	- = No offset A = 1/4 offset B = 1/2 offset	5 = 0-5 V X = 0-10 V	1 = 1 Hole 2 = 2 Holes	R = 1/2" Conduit S = PG 11 T = PG 13

## ORDERING INFORMATION

### Order Number

(See Table below and Reference Table A)

M20 - IP - PS - SO - O - KQ - KS

EXAMPLE:

M20 - 07P - C - 5 - A - 1 - R

IP = Input Pressure	PS = Power Supply	SO = Signal Output	O = Offset (See Note 1)	KQ = Knockout Quantity	KS = Knockout Size
See Reference Table A	C = 24 Vac D = 120 Vac E = 240 Vac	5 = 0 - 5 V X = 0 - 10 V	- = No offset A = 1/4 offset B = 1/2 offset	1 = Hole 2 = Holes	R = 1/2" Conduit S = PG 11 T = PG 13

MODEL M30

Two Wire / 4-20mA Output

**SPECIFICATIONS**

**Electrical**

Supply Voltage: 11 to 32 Vdc  
 (See diagram below for maximum loop resistance)  
 Protected against reversal of polarity  
 Output limited to approx. 3.85mA at low end of span and approx. 27mA at upper end of span

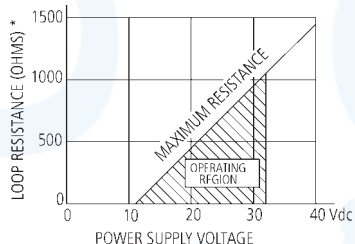

\* Loop resistance = Wire res. + Receiver res.

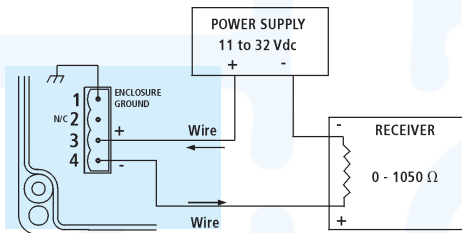

**ORDERING INFORMATION**

**Order Number**

(See Table below and Reference Table A)

M30 - IP - O - KQ - KS

EXAMPLE:

M30 - 06E - B - 1 - R

IP = Input Pressure	O = Offset (See Note 1)	KQ = Knockout Quantity	KS = Knockout Size
See Reference Table A	- = No offset A = 1/4 offset B = 1/2 offset	1 = 1 Hole 2 = 2 Holes	R = 1/2" conduit S = PG 11 T = PG 13

**NOTES**

**Note 1:**

If the measured differential pressure is expected to go from positive to negative, a transmitter with offset (elevated zero) should be ordered. Three options are available:

“-” **No offset.** At zero differential pressure, the output signal is:  
 4mA (4 to 20mA range)  
 0V (0 to 5V range)  
 0V (0 to 10V range)  
 Pressure excursion: 0% to + 100% of Range, see Table A

“A” **1/4 span offset.** At zero differential pressure, the output signal is:  
 8mA (4 to 20mA range)  
 1.25V (0 to 5V range)  
 2.5V (0 to 10V range)  
 Pressure excursion: -33% to +100% of Range see Table A

MODEL M40

AC Power Input / 4-20mA Output

**SPECIFICATIONS**

**Electrical**

Nominal Input Voltage	Power Consumption	Operating Voltage Range
24 Vac	1.5W	20 to 32 Vac
120 Vac	1.5W	90 to 140 Vac
240 Vac	1.5W	180 to 260 Vac

Isolation between power supply and output is 2500 Vrms  
 Receiver resistance can be from 0 to 650 Ohms  
 Output limited to approx. 27mA at the upper end of span

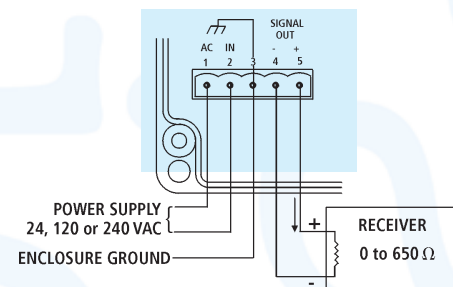

Terminals 1 and 2 are 4-20 mA current output.  
 Terminal 3 is the enclosure ground.  
 Terminals 4 and 5 are AC power input.

**ORDERING INFORMATION**

**Order Number**

(See Table below and Reference Table A)

M40 - IP - PS - O - KQ - KS

EXAMPLE:

M40 - 03M - C - A - 1 - R

IP = Input Pressure	PS = Power Supply	O = Offset (See Note 1)	KQ = Knockout Quantity	KS = Knockout Size
See Reference Table A	C = 24 Vac D = 120 Vac E = 240 Vac	- = No offset A = 1/4 offset B = 1/2 offset	1 = Hole 2 = Holes	R = 1/2" Conduit S = PG 11 T = PG 13

“B” **1/2 span offset.** At zero differential pressure, the output signal is:  
 12mA (4 to 20mA range)  
 2.5V (0 to 5V range)  
 5V (0 to 10V range)  
 Pressure excursion: -100% to +100% of Range, see Table A

To order: determine the positive pressure range; from Table A find the corresponding pressure code, then add the required offset (none, A, or B).

For example, M30 05E A\_\_\_, is a transmitter with a maximum range of 1" of H<sub>2</sub>O at 20mA and a minimum range of -0.33" of H<sub>2</sub>O at 4mA.