

WS Position Sensors

Output Specification PP530



Automation
Sensors
Measurement

1

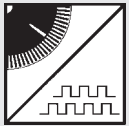
Signal Conditioner PP530 Incremental 	Excitation Voltage	+5 ... +30 VDC
	Excitation Current	200 mA max.
	Output Frequency	200 kHz max.
	Output	Linedriver, Push-Pull, CMOS, TTL and HTL compatible
	Output Current	30 mA max., Short Circuit Protection
	Output Voltage	Depends on the excitation voltage (e.g. to obtain TTL-signals the excitation must be 5 V) Compatible to EIA RS-422/RS-485
	Stability (Temperature)	$\pm 0.002\%$ / K Full Scale (sensor mechanism)
	Operation Temperature	-10 ... +70 °C
	Storage Temperature	-30 ... +80 °C
	Transition Time Positive Edge	250 ns
	Transition Time Negative Edge	250 ns
	Protection	Reverse Polarity, Permanent Short Circuit
	Immunity to Interference (EMC)	According to IEC 1000-4-2, -4, -5

Signal Diagram

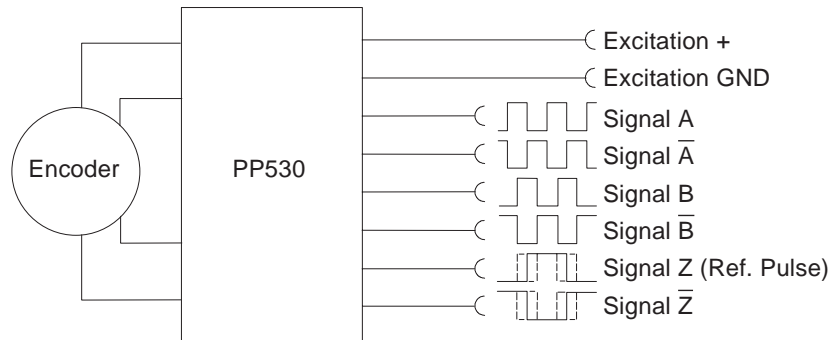

Recommended Processing Circuit

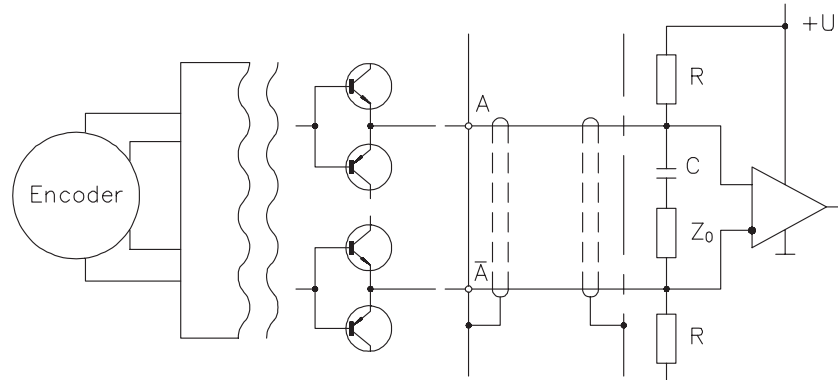

Signal Levels	Excitation	Level	$I_a \leq 5 \text{ mA}$	$I_a \leq 25 \text{ mA}$	$-I_a \leq 5 \text{ mA}$	$-I_a \leq 25 \text{ mA}$
	5 V	U_{aHigh}	$>4.2 \text{ V}$	$>4.2 \text{ V}$	$>4.1 \text{ V}$	$>3.8 \text{ V}$
5 V	U_{aLow}	$<0.5 \text{ V}$	$<1.2 \text{ V}$	$<0.4 \text{ V}$	$<0.4 \text{ V}$	
24 V	U_{aHigh}	$>23.5 \text{ V}$	$>23.5 \text{ V}$	$>23.5 \text{ V}$	$>22.5 \text{ V}$	
24 V	U_{aLow}	$<0.5 \text{ V}$	$<1.2 \text{ V}$	$<0.4 \text{ V}$	$<0.4 \text{ V}$	

Signal Wiring / Connection	Output Signals PP530	Connector WS-CONN-D8	Connector WS-CONN-066S
	Excitation +	1	A
Excitation GND (0V)	2	B	
Signal B (A + 90°)	3	C	
Signal A	4	D	
Signal B-bar	5	E	
Signal A-bar	6	F	
Signal Z (Ref. Pulse)	7	-	
Signal Z-bar	8	-	

Mating connector
View to solder terminals

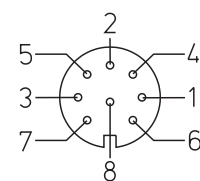

WS-CONN-D8

WS Position Sensors

Output Specifications PP24V and LD5V



Automation
Sensors
Measurement

1

PP24V Incremental

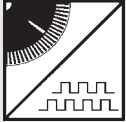

Output	Push-pull line driver (24 V - HTL)
Excitation voltage	10 ... 30 V DC
Excitation current	150 mA max. w/o load
Output frequency	300 kHz max.
Output current	100 mA per channel
Signal level	
Ud High at Id=20 mA, Ub=24 V	≥21 V
Ud Low at Id=20 mA, Ub=24 V	≤2,8 V
Transition time positive edge	< 200 ns
Transition time negative edge	< 200 ns
Stability (Temperature)	±0,002% / K full scale (sensor mechanism)
Operation temperature	-40 ... +85 °C
Protection	Short circuit, overvoltage, reverse polarity
Immunity to interference (EMC)	According to EN 50082-2, EN 50081-1

LD5V Incremental

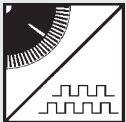

Output	Line driver according to RS-422
Excitation voltage	5 V DC ± 10%
Excitation current	150 mA max. w/o load
Output frequency	300 kHz max.
Output current	20 mA per channel
Signal level	
Ud High at Id=20 mA	≥2,5 V
Ud Low at Id=20 mA	≤0,5 V
Transition time positive edge	< 100 ns
Transition time negative edge	< 100 ns
Stability (Temperature)	±0,002% / K full scale (sensor mechanism)
Operation temperature	-20 ... +85 °C
Protection	Short circuit, overvoltage, reverse polarity
Immunity to interference (EMC)	According to EN 50082-2, EN 50081-1

Output circuit and recommended processing input circuit

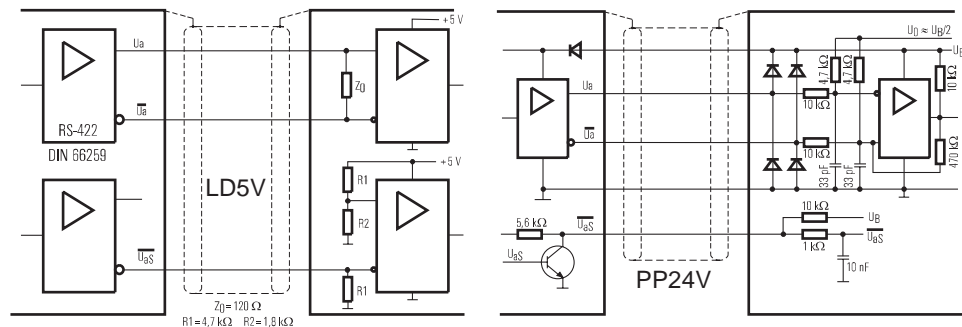

Output signals and output connectors

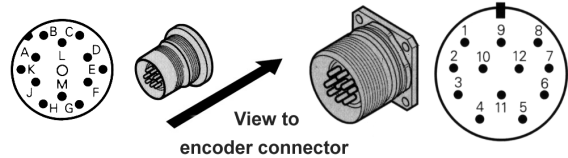
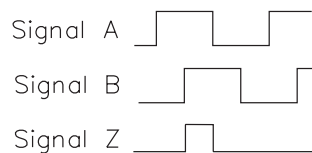

Signal wiring and connection

Output signals (Note: Do not connect pins not listed in this table)	WS19KT: WS-CONN-D12	WS19KK: WS11-CONN-12P
Excitation +	M	12
Excitation GND (0V)	K	10
Signal A	E	5
Signal \bar{A}	F	6
Signal B	H	8
Signal \bar{B}	A	1
Signal Z (reference pulse)	C	3
Signal \bar{Z}	D	4
Fault detection signal \bar{U}_{as}	G	7
Shield	Housing	Housing

WS Position Sensors

Output Specification TTL



Automation
Sensors
Measurement

1

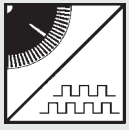
TTL Incremental 	Output	Voltage output
	Excitation voltage	4,5 ... 13,2 V DC
	Excitation current	≤80 mA
	Output frequency	200 kHz max.
	Output current	20 mA max.
	Signal level	
	Ud High at Id=20 mA, Ub=24 V	≥Ub -1 V
	Ud Low at Id=20 mA, Ub=24 V	≤0,5 V
	Transition time positive edge	< 1 μs
	Transition time negative edge	< 1 μs
	Stability (Temperature)	±0,002% / K full scale (sensor mechanism)
	Connection	Cable, length 0,5 m approx.
	Operation temperature	-10 ... +70 °C
Immunity to interference	According to EN50082-2:1995; EN55011: 1991	

Output signals

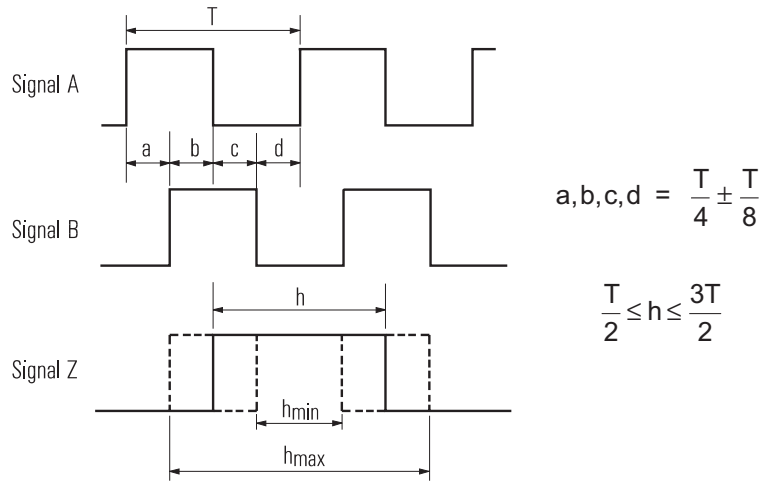

Output circuit

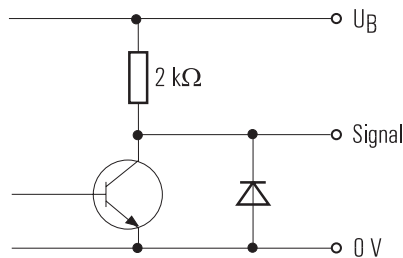

Signal wiring	Output signals	Cable colors
	Excitation +	Red
Excitation GND (0V)	Black	
Signal A	Green or blue	
Signal B	White	
Signal Z (reference pulse)	Yellow	
Shield	NC (not connected)	

WS Position Sensors

Output Specification ADSI



Automation
Sensors
Measurement

1

- Resolution 12 Bit, Data Transmission synchronous serial
- No Loss of Data at Power-down
- Easy to Connect to PLC's with SSI Input Circuit

Description

The sensing device of the ADSI is a precision potentiometer. The position information is given by an analog/digital converter output serialized as a data word. Data transmission takes place by means of the signals CLOCK and DATA. The processing unit (PLC, Micro-computer) sends pulse sequences which clock the data transmission with the required transfer rate. With the first falling edge of a pulse sequence the position of the sensor is recorded and stored. The following rising edges control the bit-by-bit A/D conversion, encoding and output of the data word.

After a delay time the next new position information will be transmitted.

Data Format (Train of 26 Pulses)

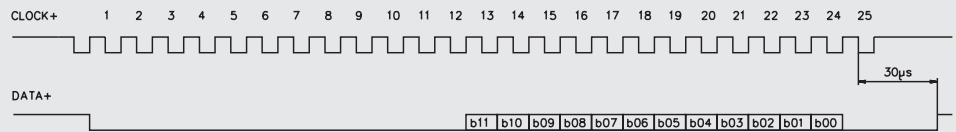

Signal Conditioner ADSI A/D converted synchronous serial

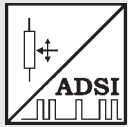

Output	EIA RS-422, RS-485, short-circuit proof
Excitation Voltage	11 ... 27 VDC
Excitation Current	200 mA max.
Clock Frequency	70 ... 500 kHz
Code	Gray Code, Continuous Progression
Delay between Pulse Trains	T=30 µs min.
Resolution	12 Bit (4096 Counts) Full Scale
Stability (Temperature)	±0,005% / K Full Scale
Operation Temperature	-20 ... +85 °C
Immunity to Interference (EMC)	According to IEC 1000-4-2, -4, -5

Recommended Processing Input Circuit

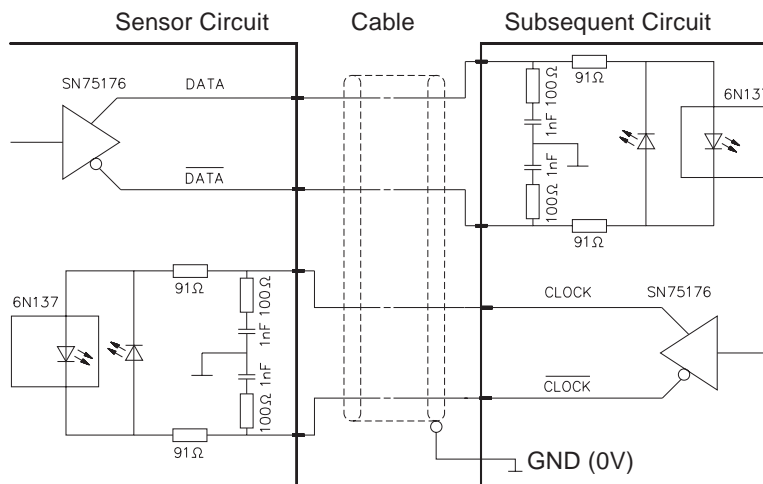

Cable Length	Baud Rate
50 m	300 kHz
200 m	100 kHz

Note:
Extension of the cable length will reduce the maximum transmission rate.
The signals CLOCK/CLOCK and DATA/DATA must be connected in a twisted pair cable, shielded per pair and common.

Signal Wiring / Connection

Signal name	Connector Pin
Excitation +	1
Excitation GND (0V)	2
CLOCK	3
CLOCK	4
DATA	5
DATA	6
Screen	not connected

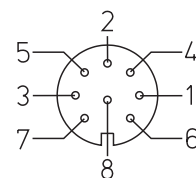

Mating Connector
View to solder terminals

WS-CONN-D8

WS Position Sensors

Output Specification TSSI



Automation
Sensors
Measurement

1

- 4096 counts per revolution (12 bit), 4096 revolutions (12 bit)
- No Loss of Data at Power-down
- Easy to Connect to PLC's with SSI Input Circuit

Description

The sensing device of the SSI is a 24-bit absolute multiturn encoder. The position information is given by an analog/digital converter output serialized as a data word. The processing unit (PLC, Microcomputer) sends pulse sequences which clocks the data transmission at the required transfer rate. With the first falling edge of the pulse sequence the position of the sensor is recorded and stored. The following rising edges control the bit-by-bit transmission of the data word. After a delay time the next new position information

Data Format (Train of 26 pulses)

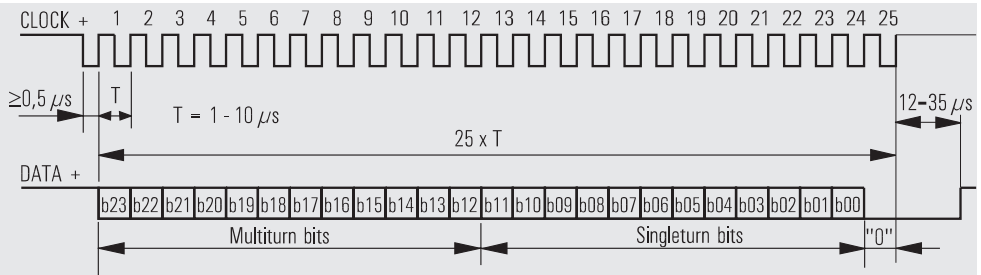

Signal Conditioner TSSI

Absolute Encoder
synchronous serial



Output	EIA RS-422, RS-485, short-circuit proof
Excitation Voltage	10 ... 30 V DC, reverse polarity protected
Excitation Current	250 mA max. without load
Clock Frequency	100 kHz ... 1 MHz
Code	Gray, continuous progression
Format	Tannenbaum
Delay between Pulse Trains	12 to 35 μs
Stability (Temperature)	±0,002% / K Full Scale (sensor mechanism)
Operation Temperature	-20 ... +85 °C
Immunity to Interference (EMC)	According to EN50082-2, EN50081-1

Recommended Processing Input Circuit

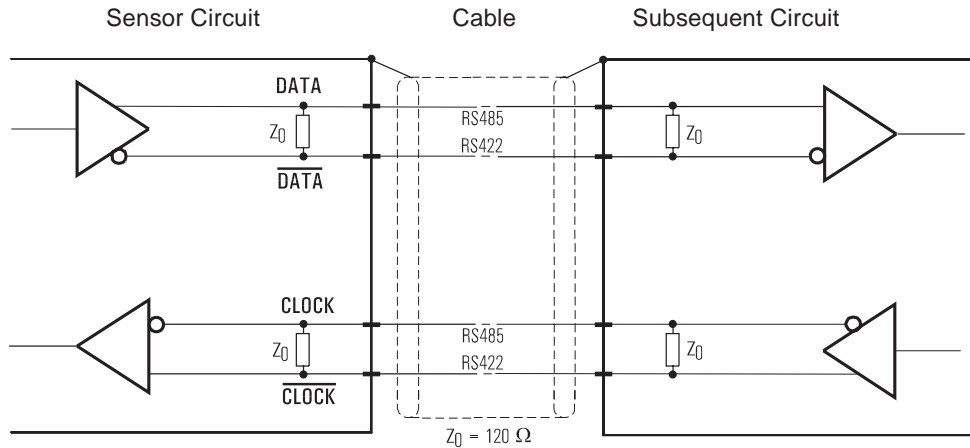

Cable Length	Baud Rate
50 m	100 ... 1000 kHz
100 m	100 ... 300 kHz

Note:
Extension of the cable length will reduce the maximum transmission rate.
The signals CLOCK/CLOCK and DATA/DATA must be connected in a twisted pair cable, shielded per pair and common.

Signal Wiring / Connection

Signal Name	Connector Pin
Excitation +	7
Excitation GND (0V)	10
CLOCK	8
CLOCK	9
DATA	14
DATA	17

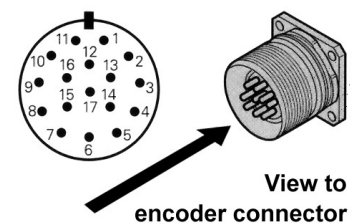

WS Position Sensors

Output Specification TSSI-P



Automation
Sensors
Measurement

1

- 8192 counts per revolution (13 bit), 4096 revolutions (12 bit)
- Encoder programming and data transfer via RS-232 interface
- In addition sinusoidal incremental signals

Description

The sensing device of the SSI is a 24-bit absolute multiturn encoder. The position information is given by an analog/digital converter as a serial data word. The processing unit (PLC, Microcomputer) sends pulse sequences which clocks the data transmission at the required transfer rate. With the first falling edge of the pulse sequence the position of the sensor is recorded and stored. The following rising edges control the bit-by-bit transmission of the data word. After a delay time the next new position information will be transmitted.

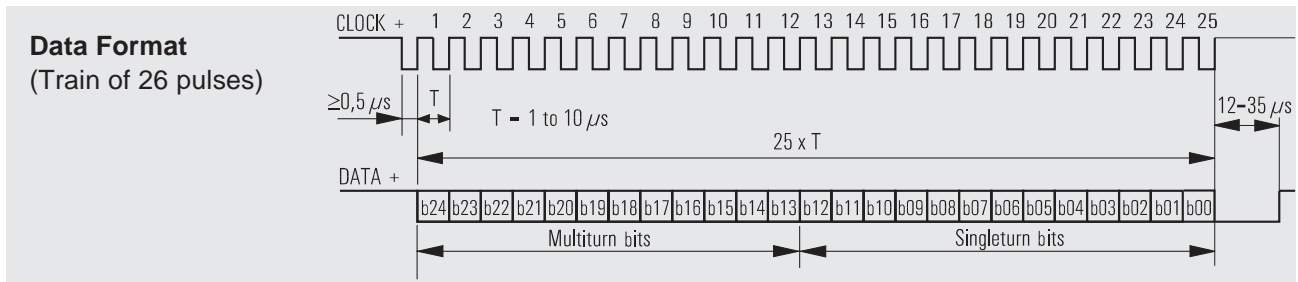

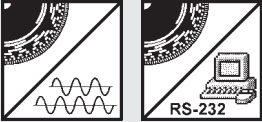
Signal Conditioner TSSI Absolute Encoder synchronous serial, programmable  	Output	EIA RS-422, RS-485, short-circuit proof
	Excitation Voltage	10 ... 30 V DC, reverse polarity protected
	Excitation Current	250 mA max. without load
	Clock Frequency	100 kHz ... 1 MHz
	Programmable Functions	Resolution, Offset, Preset, Counting Direction, Output Code and Format
	Code	Gray or Binary
	Format	Tannenbaum (SSI) or Serial, right aligned
	Delay between Pulse Trains	12 to 35 μs
	Incremental Signal	Two sinusoidal quadrature signals A and B, each with 512 periods per revolution, Signal amplitude approx. 1 V _{SS} with 120 Ω terminating resistance
	Serial Interface	RS-232C asynchronous (TxD, RxD, GND) for encoder programming and data transmission
	Hardware Programming	Preset1, Preset2, Counting Direction
	Stability (Temperature)	±0,002% / K Full Scale (sensor mechanism)
	Operation Temperature	-20 ... +85 °C
	Immunity to Interference (EMC)	According to EN50082-2, EN50081-1

Signal Name	Connector Pin
Excitation +	7
Excitation GND (0V)	10
CLOCK	8
CLOCK	9
DATA	14
DATA	17
Signal A	15
Signal A̅	16
Signal B	12
Signal B̅	13
Internal shield	11
RxD	1
TxD	4
Fault detection signal UaS	3
Preset1	5
Preset2	6
Counting direction	2

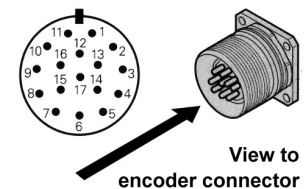

Programming Software and Connector Cable see page 69.

WS Position Sensors Output Specification TSSI-P



Automation
Sensors
Measurement

1

Recommended
Processing
Input Circuit

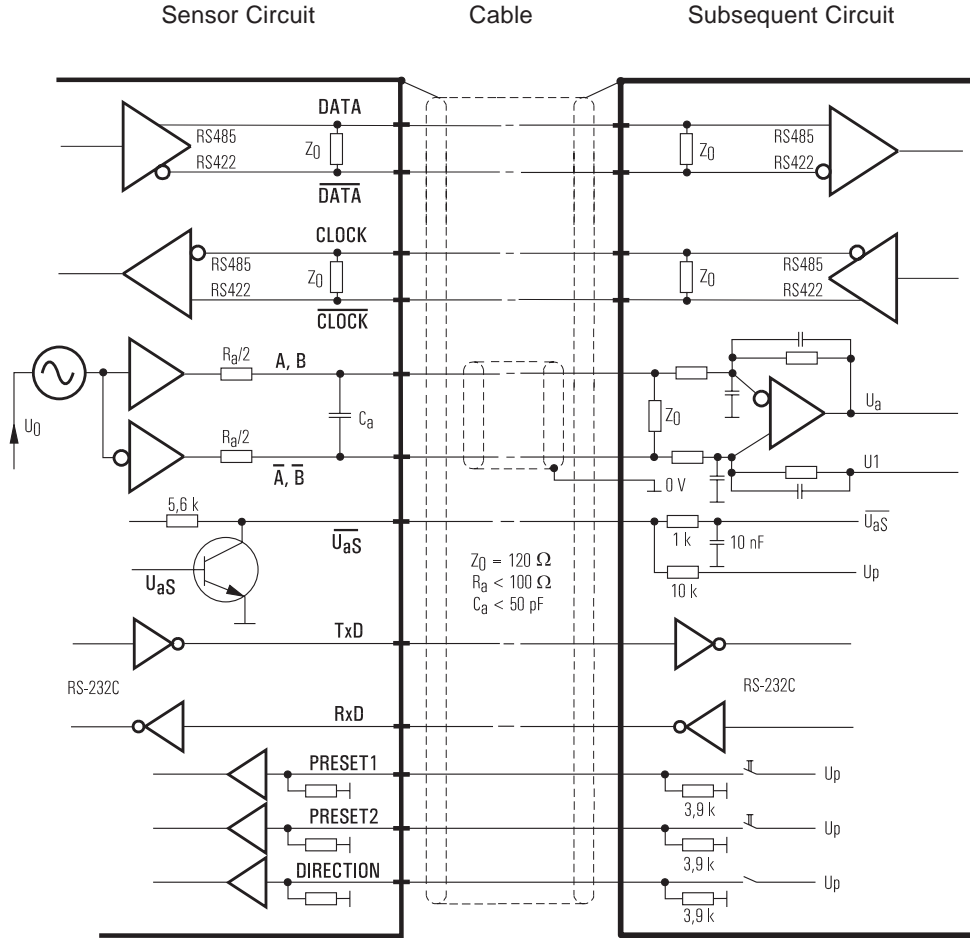

Cable Length	Baud Rate
50 m	100 ... 1000 kHz
100 m	100 ... 300 kHz

Note:
Extension of the cable length will reduce the maximum transmission rate.
The signals CLOCK/CLOCK and DATA/DATA must be connected in a twisted pair cable, shielded per pair and common.

Incremental
Signals

