

# WS Position Sensors

## Output Information

1

### Voltage Divider R1K Potentiometer

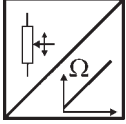

The output signal is the ratiometric voltage of a potentiometer. The potentiometer is supplied by a reference voltage source. The ratio of the output signal to the reference voltage is proportional to the measuring cable extension. For optimum performance of the sensor 94% (3% to 97%) of the potentiometers total span is used for the specified measurement range. Provision for setting the electrical zero and voltage amplification must be made in the subsequent signal processing circuit. To avoid linearity error the output load should be as low as possible. Therefore the input impedance of the processing circuit must be  $\geq 10\text{ M}\Omega$ .

### Suggested Output Circuit

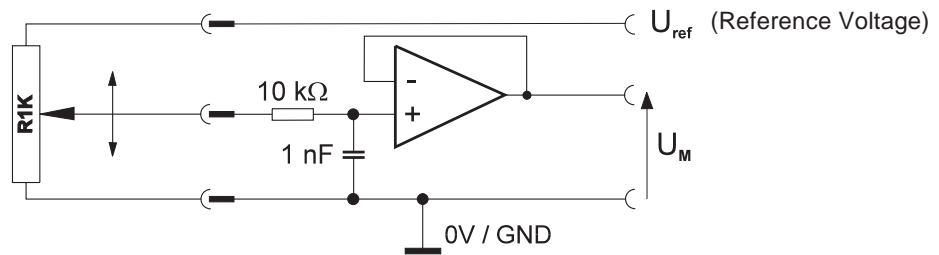

### Voltage Output 10V

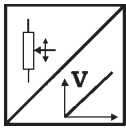

This output signal is 0 to 10 Volts proportional to the measuring cable extension of 0 to 100%. This is an industry standard output which is widely accepted because of its simple signal processing and suitability for all display, recording and automation systems. For analog signal processing the voltage output is the proven best choice, e.g. for Waveform Analyzers, Data Loggers and for analog and digital Oscilloscopes. ASM's 0...10 V output supports a wide range of excitation voltages and is well protected against electromagnetic interference.

### Suggested Output Circuit

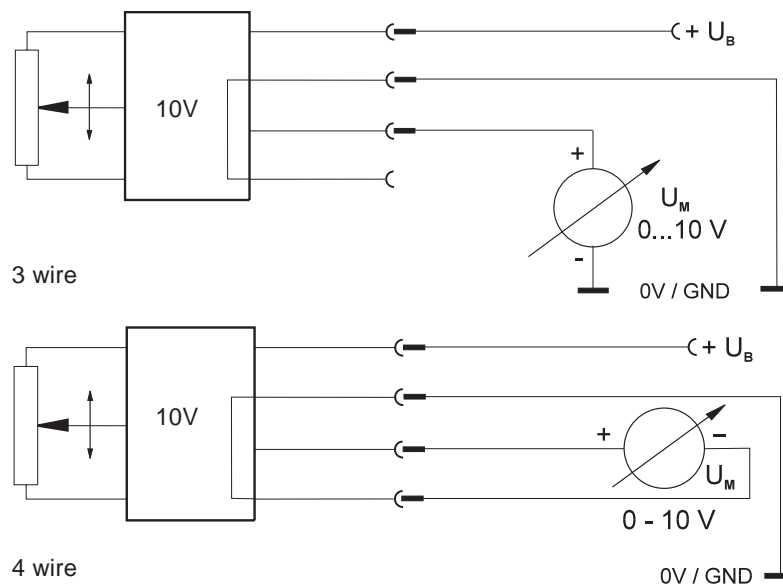

The above information is provided as a user guide only and is not part of our specific technical product data.

# WS Position Sensors

## Output Information

### Current Output 4...20 mA (420A)

2 wire

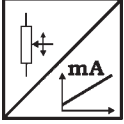

This output signal is a 4 to 20 mA current loop proportional to the measuring cable extension of 0 to 100%. It is an industry standard two-wire system for the transmission of measured values. The current loop is both measurement signal and sensor excitation current. The measured value is represented as a voltage drop across a load resistor  $R_M$ . The current is constant and the signal cable resistance ( $R_L$ ) will have no effect on the measured value. Therefore long signal cables can be used, limited only by the cable resistance (impedance). Signal cable disconnection or failure can be detected by a 0 mA current signal.

### Suggested Output Circuit

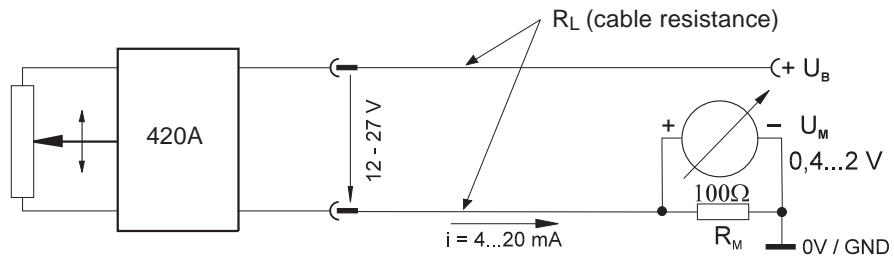

### Current Output 0 / 4...20 mA (420T, 020T)

3 wire

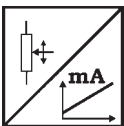

This output signal is a 4 to 20 mA current loop (alternatively 0 to 20 mA) proportional to the measuring cable extension of 0 to 100%. The 3 wire current loop system is especially resistant to electromagnetic interference because of the separate sensor excitation and the low resistance (impedance) of the signal processing electronics. As in the two-wire system the measured value is represented as a voltage drop across a load resistor  $R_M$  and is, within limits, independent of the cable resistance (impedance).

### Suggested Output Circuit

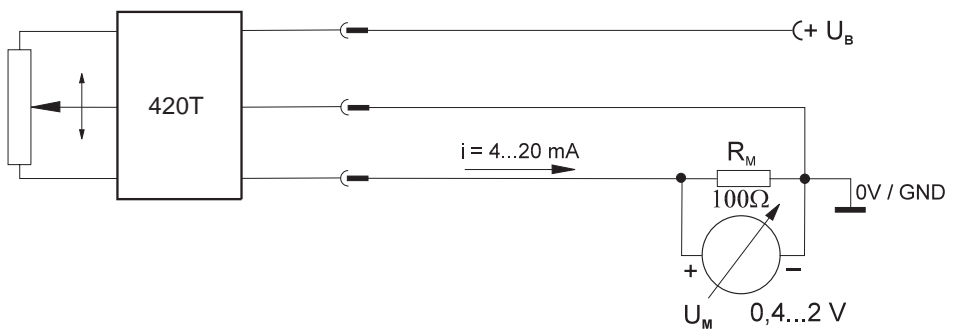

The above information is provided as a user guide only and is not part of our specific technical product data.

# WS Position Sensors

## Output Information



Automation  
Sensorik  
Messtechnik

1

### Signal Conditioner PMU, adjustable

Voltage output and Current Output

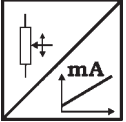
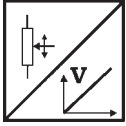

### Adjustment of Minimum and Maximum Value

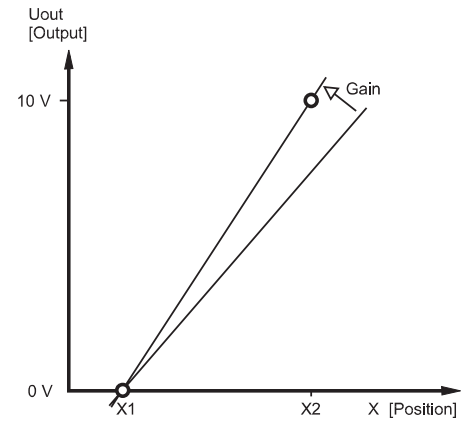
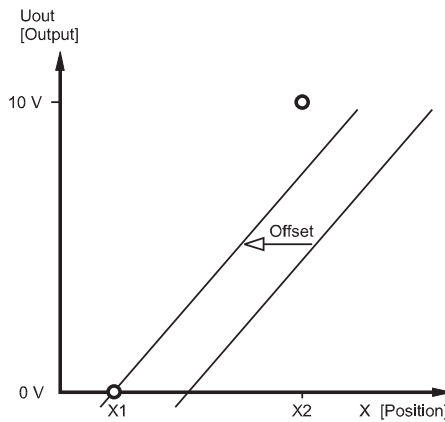

### Suggested Output Circuit (0 ... 10 V)

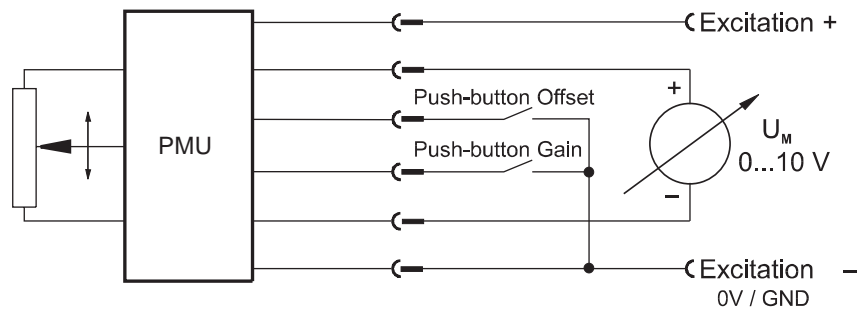

### Suggested Output Circuit (4 ... 20 mA)

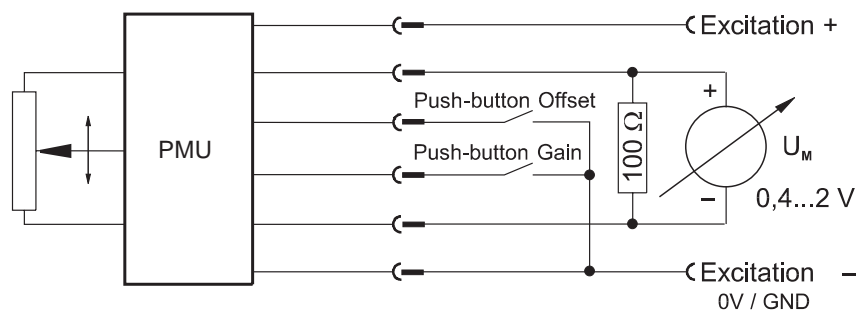

The above information is provided as a user guide only and is not part of our specific technical product data.

# WS Position Sensors

## Output Information

### Velocity Output TA

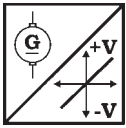

This output signal is self generated by a DC tachogenerator. The high dynamic characteristics of the tachogenerator allows measurements over a wide range of velocities. The internal resistance of the tachogenerator requires the subsequent signal processing circuit to have a high-impedance input. The exact velocity output sensitivity is specified on the sensor label for each individual sensor.

#### Suggested Output Circuit

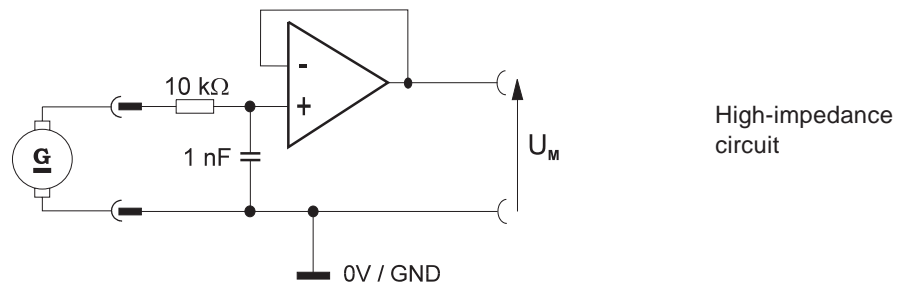

### Velocity Output T5

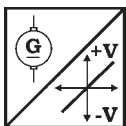

This velocity signal is taken from a DC tachogenerator of defined sensitivity and then scaled by a potentiometer. It is not necessary for the user to provide a sensitivity adjustment in the subsequent signal processing circuit. The internal resistance of the tachogenerator requires the subsequent signal processing circuit to have a high-impedance input.

#### Suggested Output Circuit

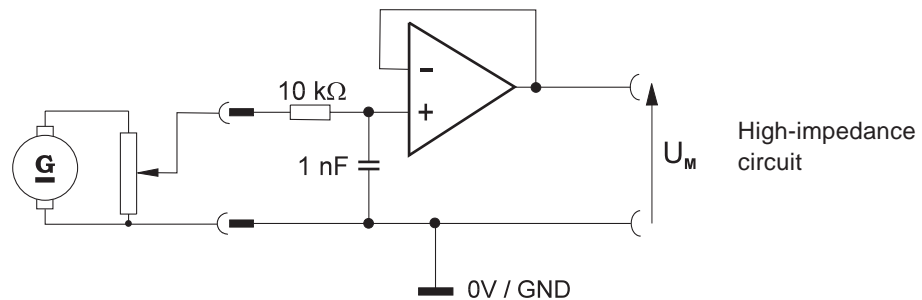

### Velocity Output VXXX

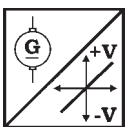

The version VXXX has an integrated signal conditioner and is suitable for the measurement of low velocities (2...100 mm/s). The output signal is a voltage of -10 V to +10 V for a linear velocity range of -100% to +100%. This industry standard output is widely accepted for electrical drive control applications.

### Incremental Output PP530

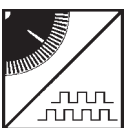

The cable extension is measured and incrementally transmitted as a sequence of square pulses. Output signals A, B in quadrature format are provided. After switching on the power the signal processing circuit can be synchronised by a periodic index (reference) pulse Z and/or a reference switch placed along the measurement range of the sensor. Because of the direct digitising and the delay-free transmission of the measured value this output is particularly good for positioning applications with high resolution requirements. Depending on the excitation voltage the output levels are compatible with TTL (5 V), RS-485 and HTL (24 V). The PP530 output is also protected against reverse polarity connection.

The above information is provided as a user guide only and is not part of our specific technical product data.

# WS Position Sensors

## Output Information

1

**ADSI**  
A/D converted  
synchronous  
serial output

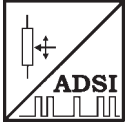

The sensing device of the ADSI is a precision potentiometer. The position information is given by the analog/digital converter output as a data word. The data transmission takes place by means of the signals CLOCK and DATA. The processing unit (PLC, Micro-computer) sends pulse sequences which clock the data transmission at the required transfer rate. With the first falling edge of a pulse sequence the position of the sensor is recorded and stored. The following rising edges control the bit-by-bit A/D conversion, encoding and output of the data word. After a delay time the next new position information will be transmitted.

ADSI is the cost-effective solution where a synchronous serial interface with a high transmission rate is required. It can be connected to all automation systems with SSI input circuits.

**SSI (TSSI)**  
Absolute Encoder  
with synchronous  
serial output



The sensing device of the SSI is a 24-bit absolute multiturn encoder. Parallel information is fed into a shift register and the processing unit (PLC, Microcomputer) sends pulse sequences which clock the shift register at the required transfer rate. With the first falling edge of the pulse sequence the position of the sensor is recorded and stored. The following rising edges control the bit-by-bit transmission of the data word. After a delay time the next new position information will be transmitted.

The SSI synchronous serial interface is an industry standard output and is supported by most suppliers of automation systems.

**RS-232**  
Serial Interface



ASM Position Sensors can be connected to a PC, a Laptop or a process automation system by using them in conjunction with the ASM Process Meters WS-UDIC, WS-CNT-RS232 or WS-SSI-RS232 which all have an RS-232 Interface (WS-CNT and WS-SSI optional). Data transmission is easily achieved with ASCII commands from any computer with standard terminal programs or from all common programming languages. Sensors with TSSI-P output have a direct RS-232 interface connection.

**Electromagnetic  
Interference and  
Cabling**

Twisted pair cables, screened per pair and common, should always be used for the sensors electrical connection. If the GND (Common) connection between the sensor and signal processing unit is not of a low resistance or different reference potentials exist then the common cable screen should only be connected at the signal processing unit end. To limit high frequency effects on sensors and signal cables the common screen should be connected at both ends and a separate GND connection between the sensor and signal processing unit must be installed. If a separate ground connection is not possible, then only one end of the cable screen should be connected to avoid current flow in the cable screen.

The above information is provided as a user guide only and is not part of our specific technical product data.