

- Measuring
- Controlling
- Monitoring

Distance Sensor M500

Laser Sensor up to 500 kHz
Measuring range 2 and 8 mm



Sensor head Type /2 /8

Weight 240 g, cable length 1 m

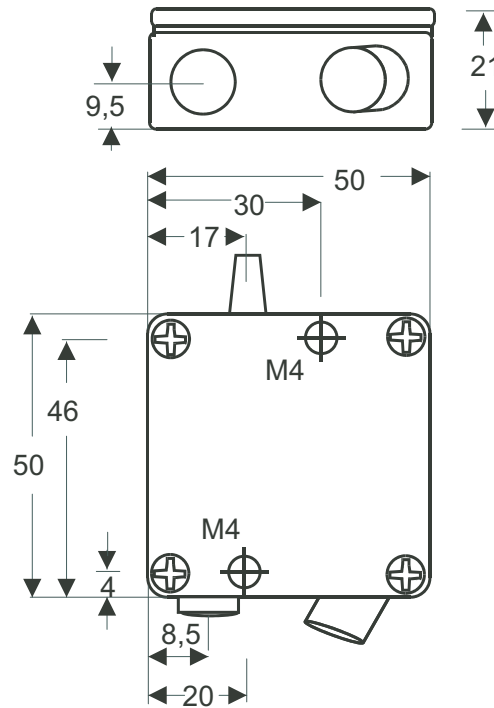

- for extreme fast measuring
- small sensor head due to separated electronic module

Laser Sensor M500

For very fast measuring

Sensor	M500L/ 2	M500L/ 8
Range [mm]	2	8
Range begin [mm]	23	47,5
Linearity* \pm [mm]	0,004	0,016
Resolution* [mm]	0,04	0,1
Light spot diameter [mm]	0,06	0,3

Light source	Laser, 670 nm, red visible
Sampling frequency	DC
Laser protection class	3R
Distance output	± 10 V
Angle error	with 15° of inclination (A-axis): approx. 0,5% on white surface
Analog outputs	Reaction time 1,2 μ s
	Bandwith 500 kHz (-3 dB)
	Temperature drift 0,07% of range / K
	Intensity output 0 ... 10 V
Switching outputs	MIN +24 V / 10 mA when lower than MIN, LED yellow
	OK +24 V / 10 mA when higher than MIN and lower than MAX, LED green
	MAX +24 V / 10 mA when higher than MAX, LED orange
	Error output +24 V / 10 mA, LED red
	Switching hysteresis 0,2% of range
	Ambient light 500 Lux - only continuous light, no artificial light (50 Hz)
	Operation time 50.000 h for Laser diode
	Isolation voltage 200 VDC
	max. Vibration 5 g up to 1 kHz
	Operation temperature +10° ... +50°C
	Storage temperature -20° ... +70°C
	Humidity up to 90% RH
	Protection class Sensor: IP 64, Electronic system: IP 40
	Supply +24 VDC / 350 mA (18 ... 28 V)

* Measurement on object color white – Bandwith 500 kHz

Delivery:

- Sensor with connection cable 1 m
- electronic unit
- 25 pin Sub-D connector for output, soldering version
- Calibration report

special types on request

Electronic unit M500

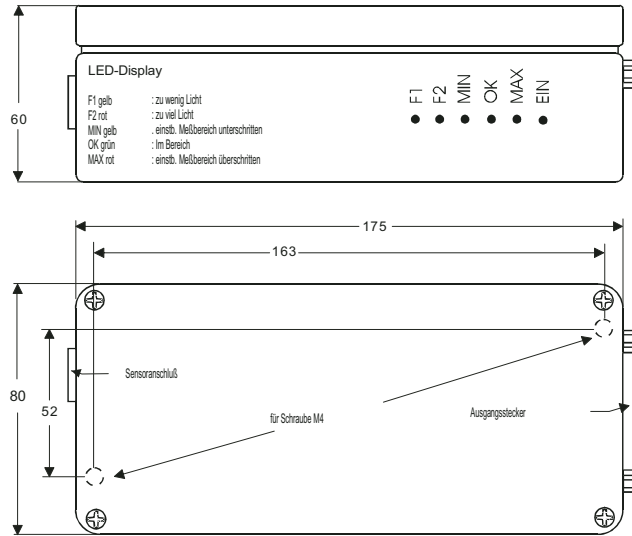

The M500 is working at DC-operation. For the adaption to fluctuations of the ambient light, the sensor is effecting a correction of this light every 0,125 to 64 ms.

To reach full speed, the sensor should operate in a casing protected against changing light (light bulb or neon lamp).

M500 Zero-point cycle

Output on pin 4 25 pin connector

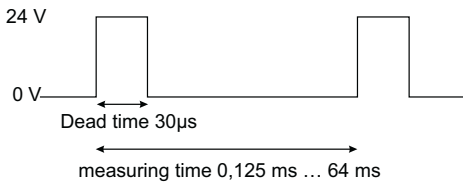

Pin assignment
25 pin SUB-D connector:

Pin	
1	Distance output ± 10 V
2	not enough light, +24 V
4	Impulse for alignment
5	Range OK, +24 V
7	external alignment
8	0V supply
14	analog GND
15	too much light, +24 V
16	MAX, +24 V
18	Intensity 0 ... 10 V
19	MIN, +24 V
21	18 ... 28 V, approx. 350 mA

This zero-point cycle will start automatically all 0,125 to 64 ms. The measuring time can be set by dip switches. If the sensor is going into the zero-point cycle, the zero set output will be high. During this time all other outputs will be undetermined.

BR 3	Intervall
1-2	64 ms
3-4	32 ms
5-6	1 ms
7-8	0,5 ms
9-10	0,25 ms
11-12	0,125 ms

