



MTN/1100IC & M1100IC Series

Intrinsically safe industrial accelerometer
Atex Group I & II approved

Applications

- General industry
- Compressors, pumps, etc.
- Oil, petrochemical & mining

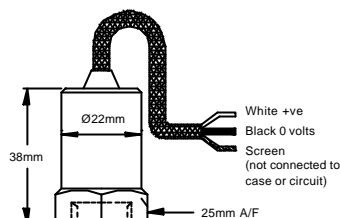

Technical Specification

Standard Sensitivity	100 mV/g $\pm 10\%$ Nominal at 80 Hz
Frequency Response	2 Hz to 10 kHz $\pm 5\%$ (-3 dB at 0.8 Hz)
Mounted Base Resonance	18 kHz (nominal)
Isolation	Base isolated
Transverse Sensitivity	Less than 5%
Electrical Noise	0.3 mg max
Current Range	0.5 mA to 8 mA
Bias Voltage	12 Volts DC (nominal)
Temperature Range	-55 to 140 °C
Case Material	Stainless steel
Cable	Integral stainless steel overbraided PTFE
Maximum Cable Length	See system drawing ATX011
Certificate Details: Group I	EEx ia I, Baseefa02ATEX0245
Group II	EEx ia IIC T6, BAS02ATEX1057
Weight	110 gms (nominal)
Sealing	IP67
System Connection	Drawing ATX011
Barrier	1 x MTL 728, BAS01ATEX7202 or P&F Z728 BAS01ATEX7005 or any other barrier that conforms to note 4 of ATX011
Options	Connector, cable length, various mounts, other sensitivities (see table)

ORDER CODE PART No	MOUNTING	xx =OPTIONAL SENSITIVITY RANGE AVAILABLE (+/- 10%)
MTN/1100IC-xx MTN/1100ICQ-xx	½ UNF FEMALE QUICK FIT FEMALE	10 mV/g 30 mV/g 50 mV/g
FOR OTHER MOUNTINGS SEE OVER PAGE.		

Mounting Adapters and Studs

Studs and Grub Screws



Male Studs		
Product Code	From	To
MS036	1/4" - 28 UNF	M6
MS039	1/4" - 28 UNF	10 - 32 UNF
MS067	1/4" - 28 UNF	M8
MS068	1/4" - 28 UNF	1/4" - 28 UNF
MS124	1/4" - 28 UNF	M10
MS132	1/4" - 28 UNF	M12

Quick Fit Adapters

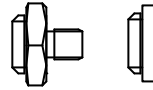

Quick Fit (Q/F)		
Product Code	From	To
MS001	Q/F Male	Glue Base
MS002	Q/F Male	M8 Male
MS003	Q/F Male	M10 Male
MS004	Q/F Male	1/4" - 28 UNF Male
MS006	Q/F Male	M6 Male

Other Adapters

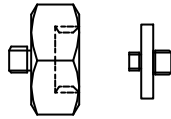

Mounting Adapters		
Product Code	From	To
MS005	Q/F Male	1/4" - 28 UNF Female
MS007	Q/F Male	10 - 32 UNF Female
MS008	Q/F Male	M8 Female
MS011	1/4" - 28 UNF Male	Q/F Female
MS013	1/4" - 28 UNF Male	Glue Base
MS033	1/4" - 28 UNF Male	Q/F Female
MS038	Q/F Male	M8 Conical Male
MS061	1/4" - 28 UNF Male	10 - 32 UNF Male
MS079	1/4" - 28 UNF Male	Q/F Female
MS106	Q/F Male	M10 Female

Isolation		
Product Code	From	To
MS034	1/4" - 28 UNF Male	1/4" - 28 UNF Female
MS093	Q/F Male	M8 Male

Barrier System Connection

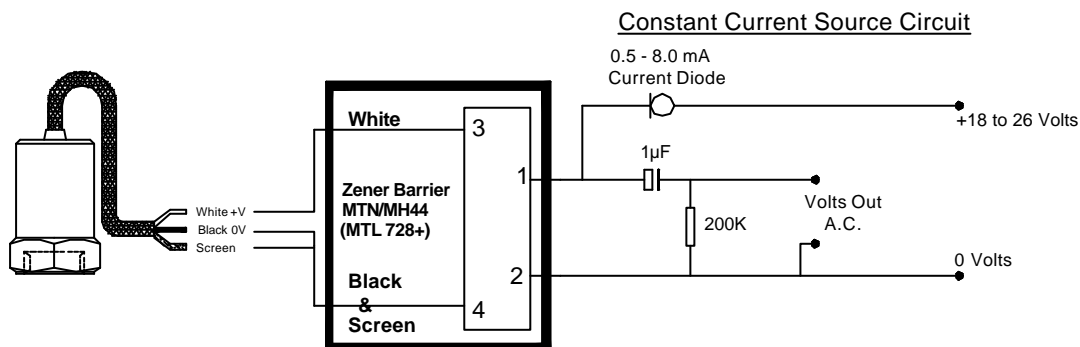

Barrier Enclosures		
Product Code	Type	Capacity
MTN/MH073	MT2	2 Barrier Capacity
MTN/MH062	MT5	2 Barrier Capacity
MTN/MH045	MT12	12 Barrier Capacity
MTN/MH024	MT24	24 Barrier Capacity
MTN/MH032	MT32	32 Barrier Capacity