



MTN/1100SCM8

Low profile side entry industrial accelerometer for restricted access installations

Applications

- Paper Machinery
- General Industry
- Pumps, Fans, etc.
- Air Handling Units
- Machine Tools

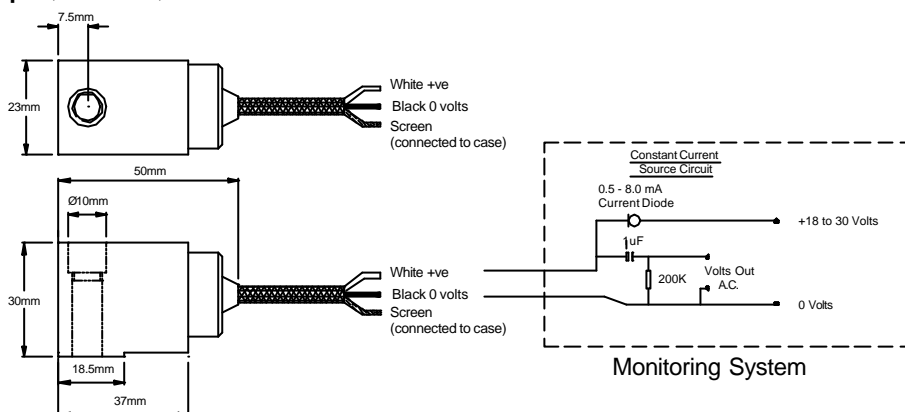

Technical Specification

| | |
|------------------------|---|
| Standard Sensitivity | 100 mV/g \pm 10% Nominal at 80 Hz |
| Frequency Response | 2 Hz to 10 kHz \pm 5% (-3 dB at 0.8 Hz) |
| Mounted Base | 18 kHz (nominal) |
| Isolation | Base isolated |
| Dynamic Range | \pm 80g |
| Transverse Sensitivity | Less than 5% |
| Electrical Noise | 0.1 mg max |
| Current Range | 0.5 mA to 8 mA |
| Temperature Range | -55 to 140 °C |
| Bias Voltage | 12 volts DC nominal |
| Case Material | Stainless steel |
| Cable | Integral stainless steel overbraided PTFE |
| Standard Cable Length | 5 Metres |
| Maximum Cable Length | 1000 Metres |
| Mounting Torque | 8Nm |
| Mounting Bolt Provided | M8 x 28mm (Captured in body) |
| Weight | 170 gms (nominal) |
| Sealing | IP67 |
| Options | Other sensitivities |